

DCP-HTR

High-Performance DC Parametric Probe

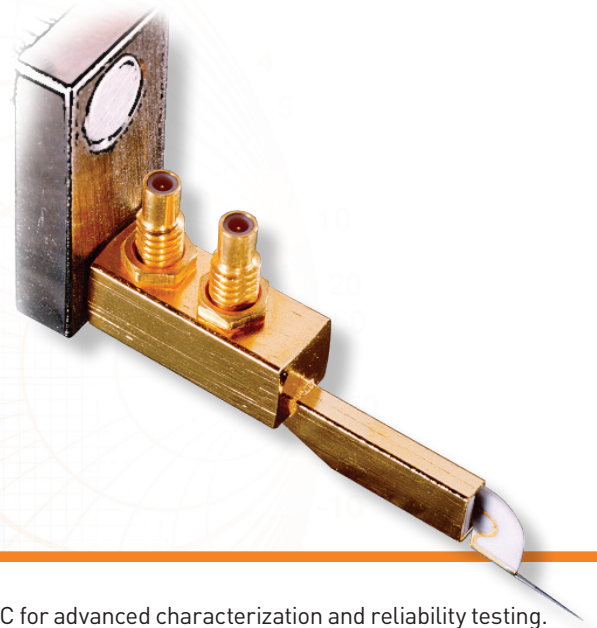

DATA SHEET

The DCP-HTR probe delivers fA-level measurement capability from -65 °C to 300 °C for advanced characterization and reliability testing. Its unique design offers superior guarding and shielding over-temperature, overcoming the high-temperature performance limitations of standard coaxial needles. For full-triaxial current/voltage over-temperature measurements, using triaxial cables, the DCP-HTR probe should be used with Cascade Microtech's parametric probing systems with MicroChamber® and AttoGuard® technology. When used with MicroChamber, the DCP-HTR allows full utilization of semiconductor parametric test instruments. The optional probe tips with small diameter are ideal for probing pads as small as 30 x 30 µm.

FEATURES / BENEFITS

Low-noise electrical performance	Ultra-low, fA-level current and fF-level capacitance measurements from -65 °C to + 300 °C
Microstrip probe tips	Guarantees fully-guarded measurements to fA and fF levels
Precision, industry-standard SSMC 50 Ω connectors	Individual connectors provide force-sense connection for quasi-Kelvin and CV measurements
Selection of probe tip styles and tip diameters	Allows probing of different pad materials and sizes
Easily replaceable probe tips	Fast replacement of worn probes without the need for tools

GENERAL SPECIFICATIONS

Breakdown voltage	>500 V
Isolation resistance	>1 x 10E ¹³ Ω
Frequency response (3 dB)	150 MHz
Mounted temperature range	-65 °C to +300 °C (above 250 °C: 8 hours max operation)
Typical leakage and noise current	±10 fA at -65 °C to 200 °C, ±20 fA at 200 °C to 300 °C
Residual capacitance	<100 fF (probe tip in air at room temperature)
Characteristic impedance	50 Ω
Body material	Gold plated
Connector type	SSMC
Minimum pad size	30 μm x 30 μm (7.5 μm or 10 μm tip diameter required)

TIP SPECIFICATIONS

Tip material	Tungsten
Contact force	3 gram/25 μm
Scrub	Typically 2.5:1 skate ratio (25 μm overdrive = 10 μm skate)
MicroChamber compatible	Yes
AttoGuard compatible	Yes

PN (10-PK)	TIP SHAPE	TIP Ø [μm]	TIP Ø TOL [μm]	DEPTH	BEAM ANGLE
154-007	flat	19	+/- 3.8	0.358	7°
154-009		13	+/- 2.6		
154-011		7.5	+/- 2.5		
154-001	radius	19	+/- 3.8		
154-003		10	+/- 2.5		

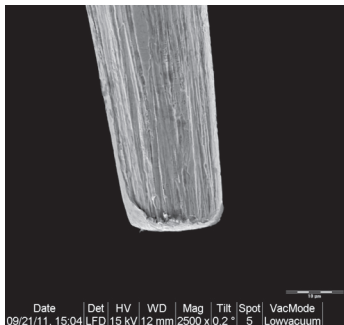

Flat Tip

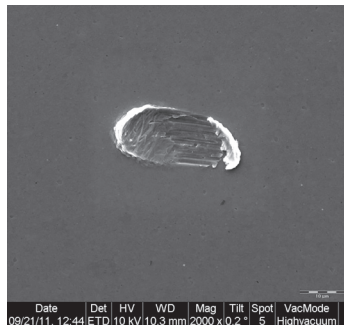

154-007 19 μm

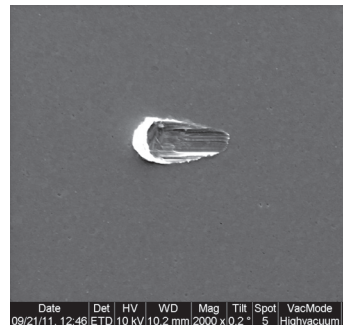

154-009 13 μm

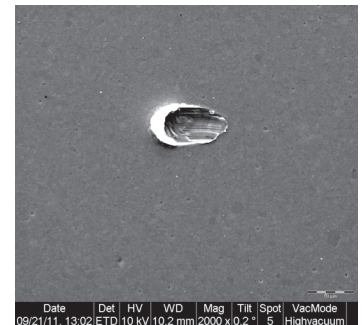

154-011 7.5 μm

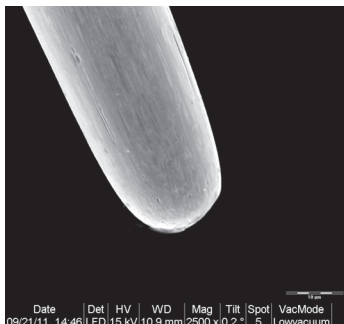

Radius Tip

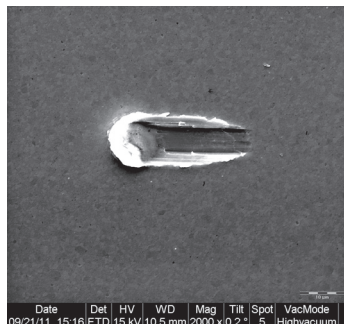

154-001 19 μm

DIMENSIONS

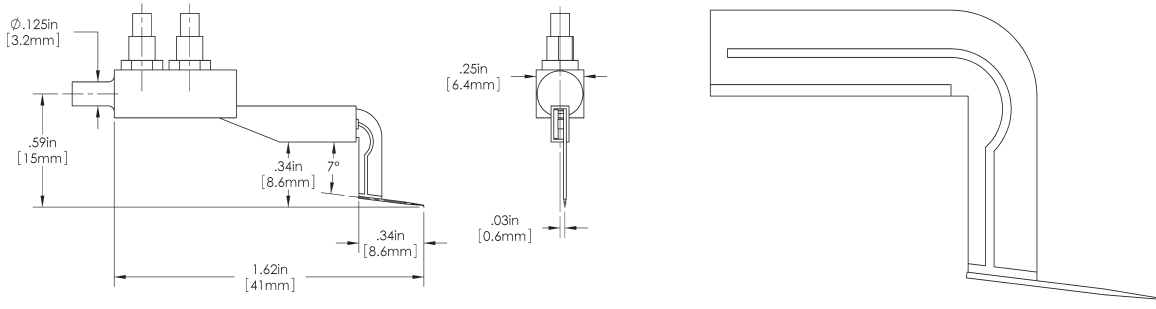

DCP-HTR Probe Body

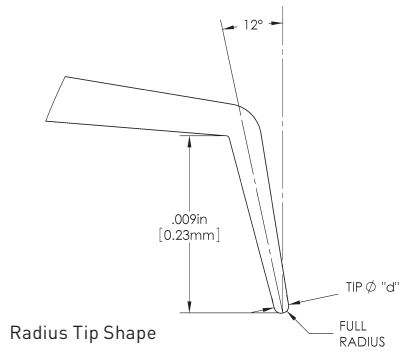

Radius Tip Shape

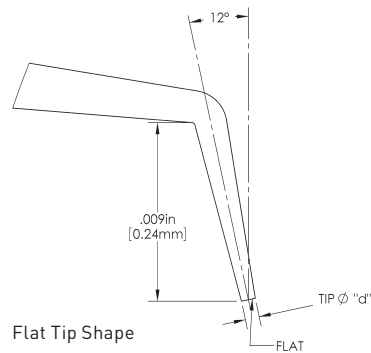

Flat Tip Shape

PERFORMANCE

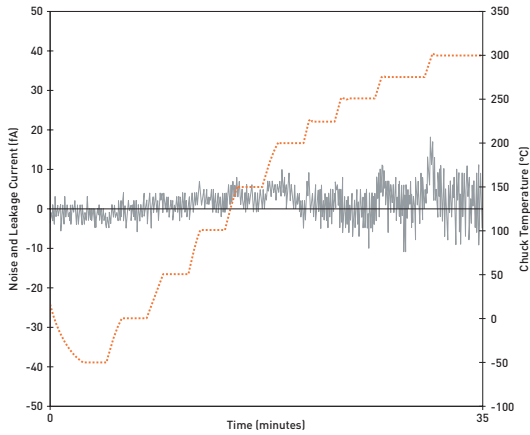

Typical DCP-HTR probe noise and leakage over temperature when used in conjunction with Cascade Microtech probe station with MicroChamber and AttoGuard technology

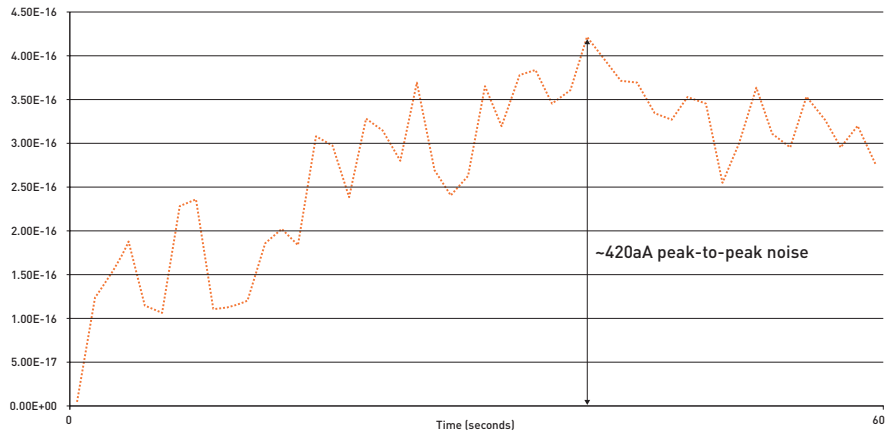

Typical DCP-HTR probe noise and leakage at ambient when used in conjunction with Cascade Microtech probe station with MicroChamber and AttoGuard technology

ORDERING INFORMATION

PART NUMBER	DESCRIPTION
DCP-HTR	DCP-HTR DC probe holder
151-286	Thermally-stable probe arms for DCP-HTR (for MS-1 positioners, triax)
151-287	Thermally-stable probe arms for DCP-HTR (for DCM positioners, triax)
151-288	Thermally-stable probe arms for DCP-HTR (for DCM positioners, coax)
154-007	Replaceable probe tips, box of 10, flat tip, 19 µm diameter
154-009	Replaceable probe tips, box of 10, flat tip, 13 µm diameter
154-011	Replaceable probe tips, box of 10, flat tip, 7.5 µm diameter
154-001	Replaceable probe tips, box of 10, radius tip, 19 µm diameter
154-003	Replaceable probe tips, box of 10, radius tip, 10 µm diameter
138-020	Edge Sense, single blade ceramic needle for DCP-HTR probe body

© Copyright 2011 Cascade Microtech, Inc.
All rights reserved. Cascade Microtech, AttoGuard
and MicroChamber are registered trademarks of
Cascade Microtech, Inc. All other trademarks are the
property of their own respective owners.

Data subject to change without notice

Cascade Microtech, Inc.
Corporate Headquarters
toll free: +1-800-550-3279
phone: +1-503-601-1000
email: cmi_sales@cmicro.com

Germany
phone: +49-811-60005-0
email: cmg_sales@cmicro.com

Japan
phone: +81-3-5615-5150
email: cmj_sales@cmicro.com

China
phone: +86-21-3330-3188
email: cmc_sales@cmicro.com

Singapore
phone: +65-6873-7482
email: cms_sales@cmicro.com

Taiwan
phone: +886-3-5722810
email: cmt_sales@cmicro.com

DCPHTR-DS-1011

DCPHTR

