

Cascade Microtech, Inc.

SPECIFICATION SHEET



The revolutionary high-resolution digital video microscope for failure analysis applications

iVistaTM LC

Digital Video Microscope

The iVista high-resolution digital video microscope is an intelligent microscopy tool, that goes far beyond simple visualisation, providing easy navigation and full prober control.

With its carefully selected optical components in combination with a high-resolution CCD camera and an intelligent frame capturing algorithm, the iVista microscope delivers an unsurpassed color image quality which is as sharp as images taken from a 16 Megapixel 1-CCD color camera. The special optical design ensures that one camera pixel is smaller than the optical resolving power. Thus the digital zoom range is only limited by the performance of the high-quality optics. The large 1.2 inch quadratic sensor fits perfectly to the optics and captures the maximum optically achievable field of view.

The iVista LC offers an optical port which fits to laser cutter systems with wavelengths 355 nm, 532 nm and/or 1064 nm from all major vendors. The automatic lens exchange unit assures an easy and hassle-free workflow by changing between a low magnification lens for navigation purposes and high-magnification lens for laser cutting purposes. The optional polarizer/analyzer unit enables liquid-crystal thermography applications and supports enhanced image contrast.

In addition to displaying a high-quality video image, the intuitive and easy-to-use software interface provides Multi View and Multi Zoom Imaging. These features display the full field of view or parts of it in combination with up to eight selectable live subviews, which can be freely defined at any position and magnification inside the full field of view. Automatic pixel-to-micron video calibration ensures correct evaluation of the image.

Full control of all motorized stages is provided by the SPECTRUMTM Vision System Software. With the on-screen joystick or point and shoot navigation, the chuck, microscope and motorized ProbeHeadsTM can easily be moved with high precision.

On-screen interaction allows a simple and quick two-point wafer alignment with just two clicks. Also with two simple clicks, features on the wafer can easily be measured.

FEATURES AND BENEFITS

Failure analysis	Optical port for laser cutter connection
	Polarizer/analyzer option for liquid crystal thermography
	High-precision lens-exchange unit for quick change between navigation and laser cutter optics
	Unlimited digital zoom range combined with Multi View Multi Zoom imaging for optimized navigation and alignment
	Image documentation with 16 megapixel effective resolution
Ergonomics and usability	Easy on-screen measurement tool
	Extremely high resolution and contrast
	One-click autofocus
	Fast two-point alignment
	Full on-screen prober control with point and shoot and on-screen joystick
	Real Multi Cam imaging shows up to four independent image sources simultaneously

PHYSICAL DIMENSIONS

Weight 10 kg (including focus block, without laser cutter)

Dimensions

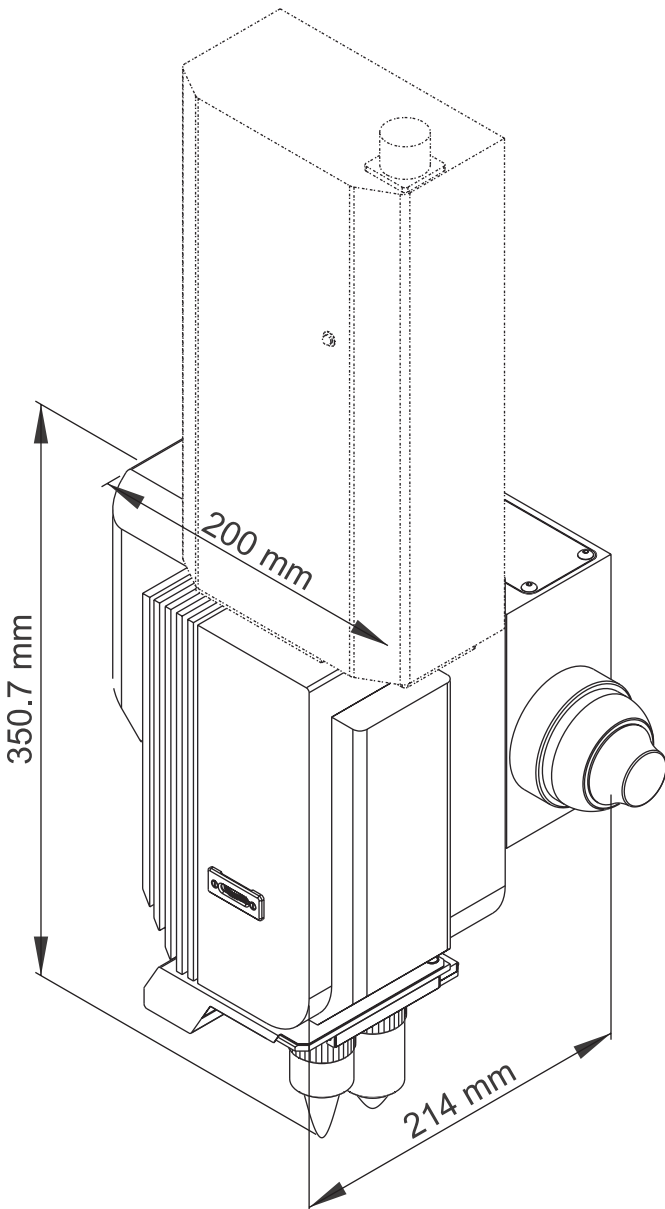

The digital video microscope iVista LC with laser cutter on a PA200 probe system.

SPECIFICATIONS*

General Features

Digital zoom range	Unlimited**
Zoom resolution	0.1x through zoom range
Zoom features	Up to eight independent freely selectable zoom areas within field of view
Auto objective lens change	Two slots ($\pm 0.5 \mu\text{m}$ repeatability)
Optical transmission range	NIR-VIS-NUV
Remote auto focus	Using chuck Z or motorized microscope movement
CCD imaging technology	Sequential exposure color imaging
Illumination system	3 color LED (solid state, long life)
Analyzer / Polarizer	Optional

Video Frame Rate

Color	15 fps (2048 x 2048 px), 29 fps (1024 x 1024 px)
Monochrome	15 fps (2048 x 2048 px), 29 fps (1024 x 1024 px)

Operating Conditions

Voltage	100 - 240 V, 50 / 60 Hz
Temperature	20°C - 50°C
Humidity	20 % - 85 %, non condensing
Recommended objective	Mitutoyo 2x, 5x, 10x, 20x, 50x, 80x, 100x, (M Plan APO, SL, NIR, NUV)
Computer requirements	Cascade Microtech-certified computer, IEEE 1394b interface required

Software Features

High resolution video	Yes (2048 x 2048 px)
Monochrome video mode	Yes (B/W or single color)
Full color video mode	Yes
Single video mode	Yes
Multi view multi zoom view	Yes, selectable 2, 3, 4, 5, 6 or 8 sub-views
Main view zoomable	Yes
Sub-view zoom function	Yes (freely selectable)
Automatic pixel to micron video calibration	Yes (semiautomatic probe station required)
Micrometer video scale superimpose	Yes (on main and all sub views separately)
Measuring tool	Yes
Multi camera mode	Yes (up to four live video feeds)
Crosshair tool	Yes (several styles selectable)
On-screen joystick	Yes (for chuck, scope or ProbeHead)
Point and shoot navigation	Yes
On-screen 2 point alignment	Yes, with two clicks
Auto focus	Yes***
Auto Z-profiling	Yes
Image capture	Yes (full resolution jpg and bmp)
Auto objective change	Yes

* Data, design and specification depend on individual process conditions and can vary according to equipment configurations.

Not all specifications may be valid simultaneously.

** Limited by resolving power of selected objective

*** Requires motorized z-movement of chuck or scope

© Copyright 2010 Cascade Microtech, Inc.
All rights reserved. Cascade Microtech
is a registered trademark and iVista,
SPECTRUM and ProbeHead are trademarks
of Cascade Microtech, Inc. All other
trademarks are the property of their own
respective owners.

Data subject to change without notice

iVista-LC-SS-0310

Cascade Microtech, Inc.
toll free: +1-800-550-3279
phone: +1-503-601-1000
email: cmi_sales@cmicro.com

Cascade Microtech GmbH
phone: +49-811-60005-0
email: cmg_sales@cmicro.com

Cascade Microtech Japan
phone: +81-3-5615-5150
email: cmj_sales@cmicro.com

Cascade Microtech Shanghai
phone: +86-21-3330-3188
email: cmc_sales@cmicro.com

Cascade Microtech Singapore
phone: +65-6873-7482
email: cms_sales@cmicro.com

Cascade Microtech Taiwan
phone: +886-3-5722810
email: cmt_sales@cmicro.com

www.cascademicrotech.com

