



Mechanical Layout Rules for Infinity Probes®

See it. Touch it.
Measure it.®



Introduction

Cellular phones, wireless networks (e.g. WLAN), fiber optic communications, automotive communications (e.g. CAN-bus) and the Internet have all benefited from faster and more reliable connections. This increased demand, particularly among consumer applications, has shortened product life cycles, thus increasing the pace of RF technology development. To remain competitive engineers must reduce cycle times and cost.

To address these issues, high frequency (GHz) probes were developed and have significantly advanced on-wafer modeling and characterization capabilities. Wafer probing at GHz frequencies has developed from a simple R&D curiosity to a sophisticated high-volume tool used in the development and manufacturing of GaAs, Si, SiGe, high frequency packaging, and hybrid technologies. The advancements made by Si-based technologies have also introduced the additional challenge of probing aluminum pads.

Cascade Microtech's newly developed Infinity probe technology has been designed to not only meet the challenges of high frequency probing but also to meet the demands of stable contact resistance on aluminum pads. Successful high frequency probing also requires that consideration be given to layout and design before design completion and mask fabrication. Failure to observe specific layout requirements can result in the inability to test devices with high frequency probes.

This Application Note focuses on the mechanical (physical) layout issues as they apply to the use of Infinity high frequency probes. These rules insure that a fabricated device can be successfully probed.

It is useful to stop and consider what you really wish to measure. When high frequency probes are used with a network analyzer (after calibration), what is measured will be what the probe tips contact. This includes the pad parasitics, and parasitics associated with the interconnects from the pad to the other devices on your substrate. If you want to measure a device independent of the pad effects, then it is useful to make the pads small, so their effects will be negligible or easily subtracted (de-embedded) from the measured data. In any event, it is important to be clear that when using a network analyzer you will be measuring everything past the end of the probe tips, unless you use special calibration/correction techniques. In most applications this is exactly what you want; a measurement of the circuit's electrical performance.

Probe Features Affect Layout

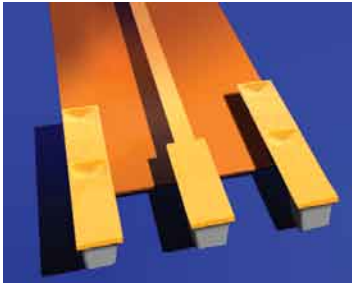

Figure 1: Infinity's microstrip transmission line construction reduces unwanted coupling

Figure 2: Electric field patterns transitioning from coax, to microstrip, to the DUT.

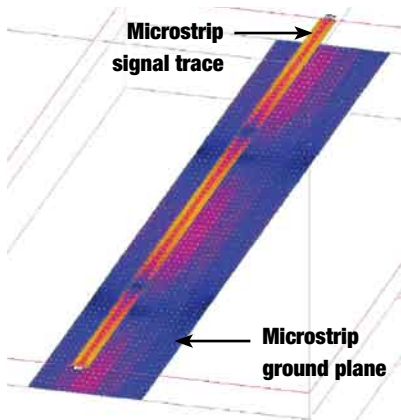
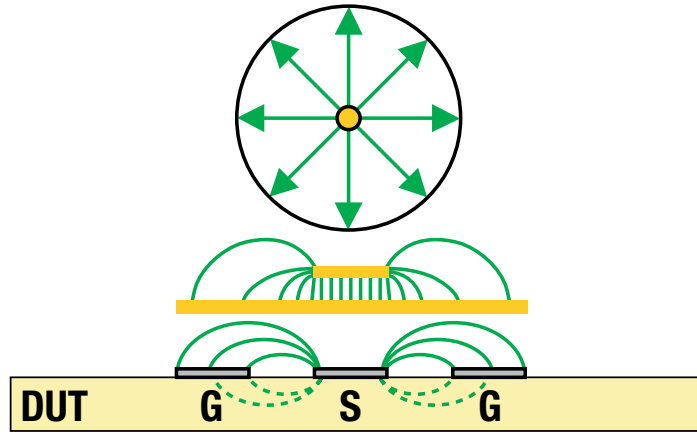

Figure 3 Traveling-wave voltage in microstrip

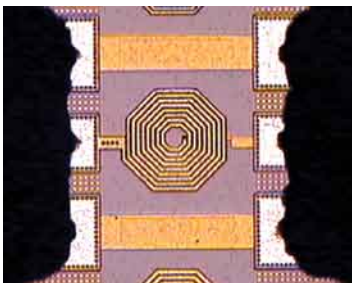

Figure 4: High frequency characterization of a spiral inductor

A probe's features include the coaxial connector, the probe body, the probe tip, and the contacts at the probe tip end. In the Infinity probe microstrip transmission lines carry the signal between the coaxial connector and the coplanar probe tip contacts (Figure 1).

The transition from coaxial, with a radial electrical field pattern, to a microstrip transmission line with a much different (flatter) electrical field pattern (Figure 2) is made within the probe, which still has to make contact with the DUT. This is a difficult transition to make at high frequencies, and presents significant challenges in successfully developing this type of probe. The best DUT test results if the electric field patterns at the probe tip are similar to the field patterns in the DUT and when there is minimum parasitic coupling to the probe. The superior field confinement offered by Infinity's microstrip construction reduces this type of unwanted signal energy.

The typical probe contact is a signal (S) or ground (G) contact. The signal contacts are electrically connected to a coaxial connector center pin, and the ground contacts are electrically connected to the coaxial-connector body. At high frequencies the ground is not an equipotential reference (Figure 3), as in low frequency circuits, but is a part of a transmission line that contains time-varying electric fields. When laying out the pads for wafer probing, placement of ground pads, relative to the signal pads is an important consideration. It is recommended that the ground pads be no further than 0.05λ (highest test frequency wavelength) for GSG configurations and 0.02λ for SG/GS configurations. Also if the connection to the DUT is from co-planar pads that transition to microstrip, then the spacing to the co-planar ground pads should be $2.5X$ the width of the microstrip's signal line.

Figure 4 shows a spiral inductor that has been laid out for two-port high frequency characterization. In this case Ground-Signal-Ground (GSG) probes have been used. The top and bottom pad pairs have been connected forming a low impedance ground path between the two ports and the center pair of pads form the signal path. This probe configuration, GSG, achieves excellent broadband performance. The GSG probe configuration achieves this higher performance from the short symmetrical field termination paths to ground (Figure 2). Figure 5 shows the longer, and asymmetric electric field patterns of a SG probe, which while reducing the number of pads required for probing, also reduces the measurement bandwidth. This change in the ground path length can be modeled as an increase in common mode inductance. Measurements have been made showing the SG/GS probes have about four times as much common mode inductance as GSG and there is a corresponding reduction in useable bandwidth. This phenomenon becomes more apparent at larger pitches and higher frequencies.

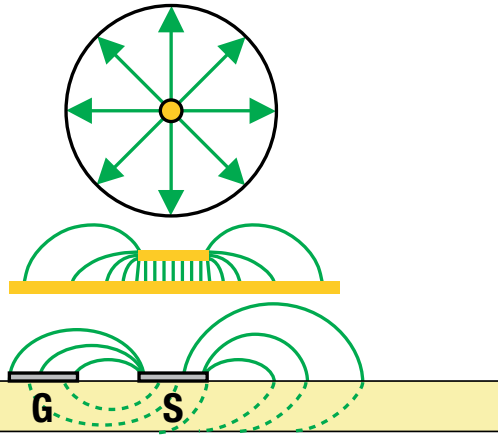

Figure 5 Asymmetric electric field of a SG probe

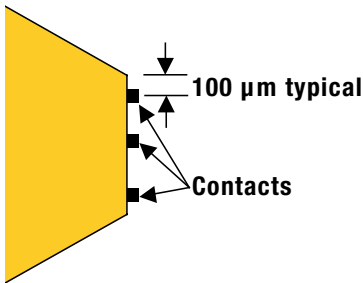
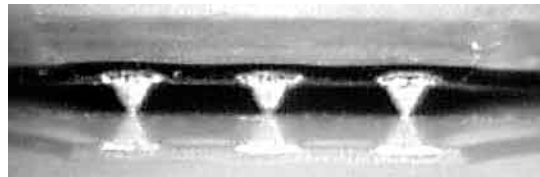

Figure 6: Substrate extension is typically 100 μm

Figure 7: Infinity Probe 12 μm tip—the three probe contacts are also seen as reflections in the DUT surface



There are several physical features of Infinity probes that affect the physical layout. The first of these (Figure 6) is the extension of the probe tip substrate material and epoxy overcoat past the center of the contact closest to the edge. This dimension is typically 100 μm . Probes must not be allowed to collide, so this 100 μm extension must be considered when laying out pads.

Another physical layout consideration is the probe contact size (Figure 7), typically 12 x 12 μm . Note that these contacts might be larger than needle probes, and the passivation windows must be large enough to accommodate these contacts plus typical probe system variations.

The final consideration is the probe skating distance. For every 50 μm of overtravel (overtravel is the continued downward movement after the probe tip has made initial contact with the wafer) the probe contacts will skate laterally 25 μm (2:1 OT to skate ratio). If the probes are too close together, they could skate into each other and be damaged. The layout rules will help you to prevent probe collisions.

Sequence of Layout Events

The following are guidelines to the typical sequence of events involved in layout for testing with Infinity probes.

1. **Select basic pad footprint** for ground-signal-ground (GSG), or signal-ground (SG) / ground-signal (GS), to be consistent with input/output type (see step 2), and if applicable, package requirements.
2. **Orient high-gain signal pads** away from each other. Typical microwave devices place inputs on the left, and outputs on the right
3. **The ground pads** for each Infinity probe must be electrically connected together on the input and output (see Figure 4) to provide a low-impedance common-ground node.
4. **Verify that pad pitch matches available probe pitch** (see Cascade Microtech RF Probe Selection Guide). Also, verify that the pad footprint meets potential packaging requirements.
5. **If you must violate any of the layout rules**, please call the Cascade Microtech Applications Group regarding the trade-offs and to verify that the footprint is a good layout for probing. Some of the rules can be successfully violated, provided you meet certain conditions.

Layout Rules

This section describes the rules regarding probe pad placement and sizing. In many designs the probe pads are also used as bond pads, so the final layout may need to satisfy requirements for both probing and bonding. A good layout for probing is usually also a good layout for packaging.

There are two important probe mechanical parameters, which directly affect the mechanical layout rules; the contact dimensions and the substrate extension past the contact. Typical contact size for Infinity series probes (Figure 7) is $12 \times 12 \mu\text{m}$. The contact size is important because the passivation window must be large enough to allow the entire contact to touch the pad. The substrate extension is typically $100 \mu\text{m}$ past the contact center (Figure 6).

Infinity probes are constructed with all contacts in a straight line, and with equal spacing between contacts. This means that all pads, arranged for an individual high frequency probe measurement, must be in a straight line, have equal pitch, and be on the substrate top. Non-square or very large pads may be laid out more randomly, as long as there is a minimum-size land area, spaced at an equal pitch for the probe contacts to land on.

Topside pads connected to substrate vias must be used to contact backside grounds. All pads must have minimal height variation, because probe construction allows little contact height variation.

If the probes skate into each other, they can be damaged. The pad layout must allow for sufficient damage avoidance space between probes. Provide sufficient space for probes that are oriented 90 degrees to each other, as well as between probes that face each other. There must be sufficient space between probes to allow for probe skating. The following pad layout rules allow for vertical overtravel of 6 mils ($152.4 \mu\text{m}$). Note that 6 mils is the maximum suggested overtravel for Infinity probes, and that the recommended nominal overtravel (to achieve assured contact) for the typical probe is 2-3 mils ($50\text{-}75 \mu\text{m}$).

If you have a specific need outside these values, please call the Cascade Microtech Applications Group for consultation.

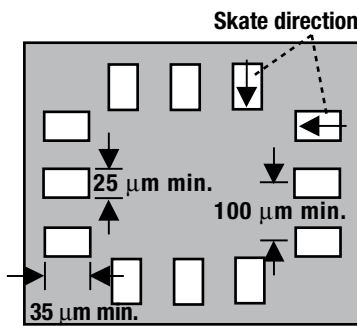

Figure 8: Rules 100 and 102.
Minimum pad size is $25 \times 35 \mu\text{m}$.
Minimum pad pitch is $100 \mu\text{m}$ for general use ($50 \mu\text{m}$ for fine pitch probes).

Rule 100 Pad size (Figure 8) The minimum pad size for manual probe placement is $25 \times 35 \mu\text{m}$. (Note the longer dimension on the rectangular pad is in the direction of probe skate.) The recommended minimum pad size for general use (auto or semi-auto probe placement) is $50 \times 50 \mu\text{m}$. For narrow pitch probes (e.g. 50 or $75 \mu\text{m}$ pitch) minimum pad size is $30 \times 50 \mu\text{m}$. Unless you have a good reason to do otherwise, use $100 \times 100 \mu\text{m}$ pads with a $150 \mu\text{m}$ pitch. This provides for easy probing, and parasitics are low enough for many applications.

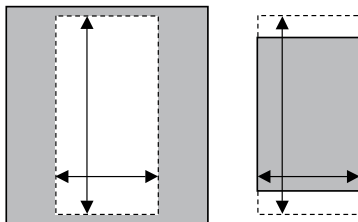

Figure 9: Rule 101 Minimum passivation window size, represented by the dotted lines, is $25 \times 44 \mu\text{m}$. Having the passivation window larger than the probe pad is not recommended

Rule 101 Passivation window The minimum passivation window size is $25 \mu\text{m} \times 44 \mu\text{m}$ (Figure 9). Note that for small pad sizes, the passivation window will be larger than the pad. However, because of reliability considerations, it's not considered good practice to have the passivation window larger than the probe pad. If the pad metalization is above the final passivation layer, this rule does not apply. To provide clearance for the probe tip, the distance from the top of the probe pad to the top of passivation layer should not exceed $40 \mu\text{m}$ (Figure 10). Lastly the passivation window must allow the probes tips to come to rest in their measurement position $25 \mu\text{m}$ from the leading-edge of the probe pad (Figure 10). This position corresponds to the same pad overlap that is used during calibration.

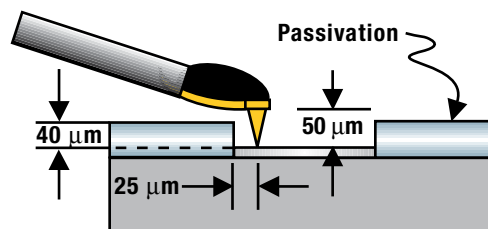

Figure 10: Maximum passivation thickness is $40 \mu\text{m}$ above the probe pad

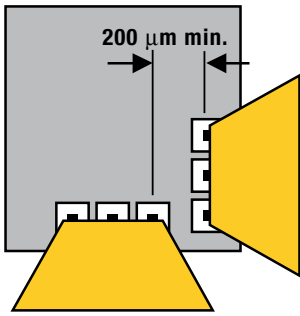

Figure 11: Rule 103 Minimum center-to-center pad spacing in a corner is 200 μm.

Figure 12: Rule 104 Minimum pad spacing with opposing, side-by-side probes is 200 μm.

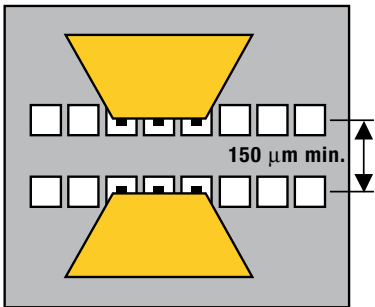
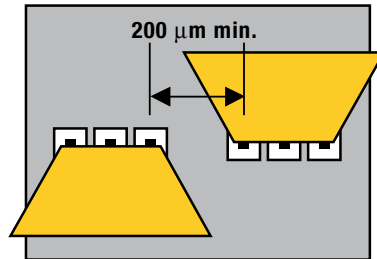

Figure 13: Rule 105 Minimum center-to-center pad spacing for parallel rows of pads with facing probes is 150 μm

Rule 105 Parallel-row pad spacing The minimum center-to-center pad spacing between facing probes on parallel rows of pads (Figure 13) is 150 μm. Note that this spacing is based on the assumption that no more than 6 mils (150 μm) of probe over-travel (maximum allowed overtravel) is applied.

The purpose of this rule is to avoid potential excessive overtravel conditions which may result in contact between opposing probes. For some cases (e.g. 138-356 ISS with 0.5 ps thru) it may be necessary to reduce this spacing to 65 μm.

Rule 106 Pad height variation The maximum pad height variation in a row of pads contacted by one probe is 0.5 μm (Figure 14). Pad height variation usually occurs because pads are constructed with different metal stacks. Be sure to use the same metal layers to construct all pads.

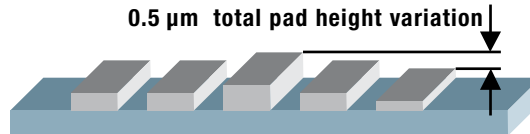

Figure 14: Rule 106 Maximum pad height variation in a row of pads contacted by one probe is 0.5 μm.

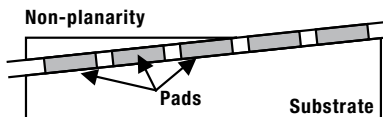
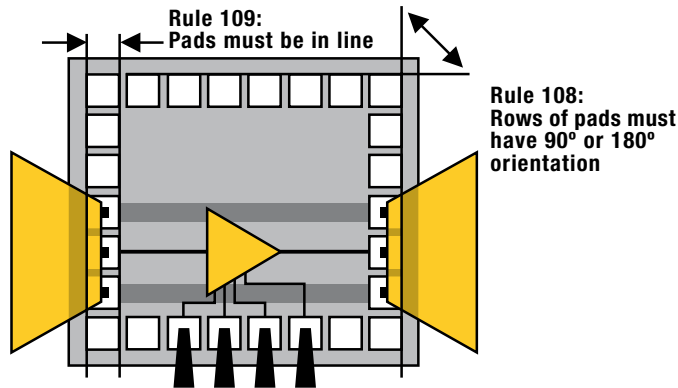

Figure 15: Rule 107 Maximum non-planarity from a row of pads to the backside of substrate is 2000 ppm.

Rule 107 Planarity requirements The maximum overall planar deviation of a row of pads contacted by one probe, with respect to the backside of the substrate, is 2000 ppm (Figure 15). Another way of stating the maximum deviation is to say for every 1mm of X or Y change the maximum Z change should not exceed 2 μm. Non-planarity can be caused by using different metal stacks for the pads within a row; incorrectly backlapping a wafer; or just local variation in the substrate thickness (Global planarity can be compensated for with the RF positioners; ± 3.5° of planarization range). Also note that during probing, non-planarity between the probe contacts and the pads should not exceed these maximum planar deviations.

Rule 108 Pads at 90 degrees only Rows of pads meeting at an angle must be orthogonal (at 90 degrees). (Figure 16)

Figure 16: Rule 108: ROWS of pads meeting at an angle must be at 90 degrees. Rule 109: Pads contacted by one probe must be collinear.



Rule 109 Pads are collinear All pads contacted by an individual probe must be collinear (Figure 16)

Rule 110 Pads have equal pitch All pads contacted by an individual probe must have constant pitch.

Rule 111 Pads on top All probe pads must be on the substrate top.

References

- [1] Williams, Dylan F.; and Miers, Tom H.; "A Coplanar Probe to Microstrip Transition;" *IEEE Transactions on Microwave Theory and Techniques*; Vol. 37, No.7, July 1988, pp 1219-1223.
- [2] Fraser, A.; Gleason, Reed; Strid, Eric; "GHz On-Silicon-Wafer Probing Calibration Methods" *Proceedings of the 1988 Bipolar Circuits and Technology Meeting*; pp 154-157.
- [3] P. J. van Wijnen, et al.; "A New Straightforward Calibration and Correction Procedure for 'On Wafer' High Frequency S-parameter Measurements" *Proceedings of the Bipolar Circuits and Technology Meeting*; 1987.



Cascade Microtech, Inc.
2430 NW 206th Ave., Beaverton, Oregon 97006, USA
Toll Free: +1-800-550-3279 Phone: +1-503-601-1000
Europe: +44-1295-812828 China: +86-21-6340-4183
Japan: +81-3-5478-6100 Singapore: +65-6873-7482
Taiwan: +886-3-5722810
Email: sales@cmicro.com <http://www.cascademicrotech.com>
Copyright © 2006 Cascade Microtech, Inc. All rights reserved.
All trademarks are the property of their respective owners.

INFINTYRULES-AN-1006
Data subject to change
without notice