

This guide contains information to help prepare your facility for the arrival of your EP6 probe station.

Probe Station Requirements

| | | |
|---------------------------------------|--|--|
| Design Versions | EP6 DC | Basic DC probe station with four probe positioners with DC front plate |
| | EP6 RF | Basic RF probe station with two probe positioners and HF kit |
| Air and Vacuum | Vacuum | <ul style="list-style-type: none"> • Less than 200 mbar absolute • Flow rate insignificant • 8 mm hose (US 5/16") |
| | Compressed air | n/a |
| Dimensions | Station | 510 mm (W) x 600 mm (D) x 480 mm (H) |
| Weight | Station | 40 kg |
| Temperature | Operating range | 19°C to 24°C |
| | Target temperature | 22°C |
| | Tolerance | 1K |
| Humidity | Tool area | 25% to 60% |
| Vibrations | The facility should be free of vibrations caused by other equipment. | |
| Electrical Data | Power for accessories | 100–240 V AC nominal, 50/60 Hz, 500 VA (depends on accessories and country/region) |
| Pollution Level | 1 IEC 664 | |
| Clean Room Class | Class 6 corresponding to DIN EN ISO 14644-1 | |
| Additional Equipment | Video option | 1/2" CCD PAL Camera and 17" monitor |
| | Table | Extra space may be required for additional equipment (such as measurement devices) next to the probe system. |
| | Low-signal measurement option | Extra space is required for the PC next to the probe system. |
| | Vibration isolation table | For dimensions and feet support points, see diagrams. |
| Shipping Dimensions and Weight | Probe station box | <ul style="list-style-type: none"> • 710 mm x 920 mm x 890 mm • Gross weight: 100 kg |

Vibration Isolation Table Dimensions

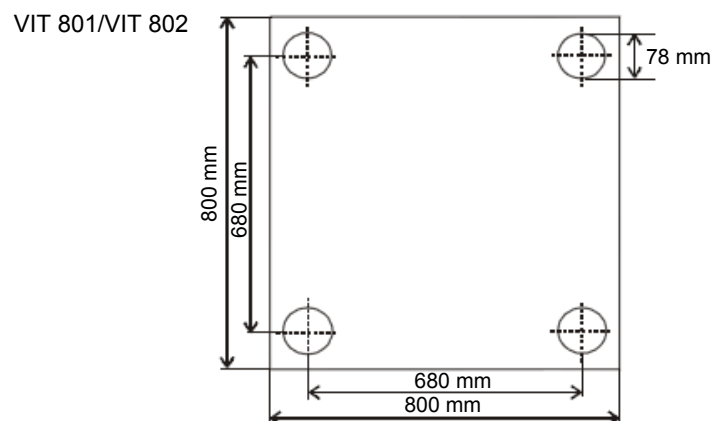
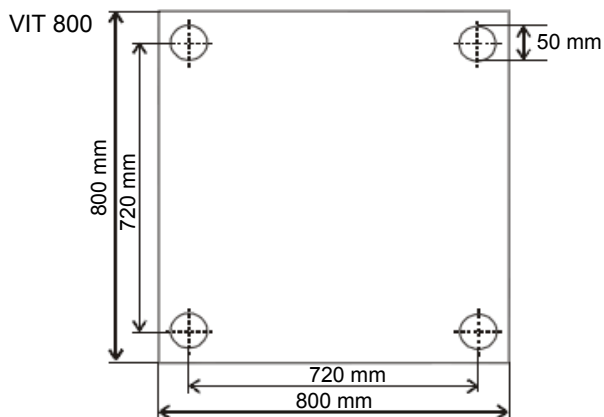

EP6 Probe Station

EP6 Front View

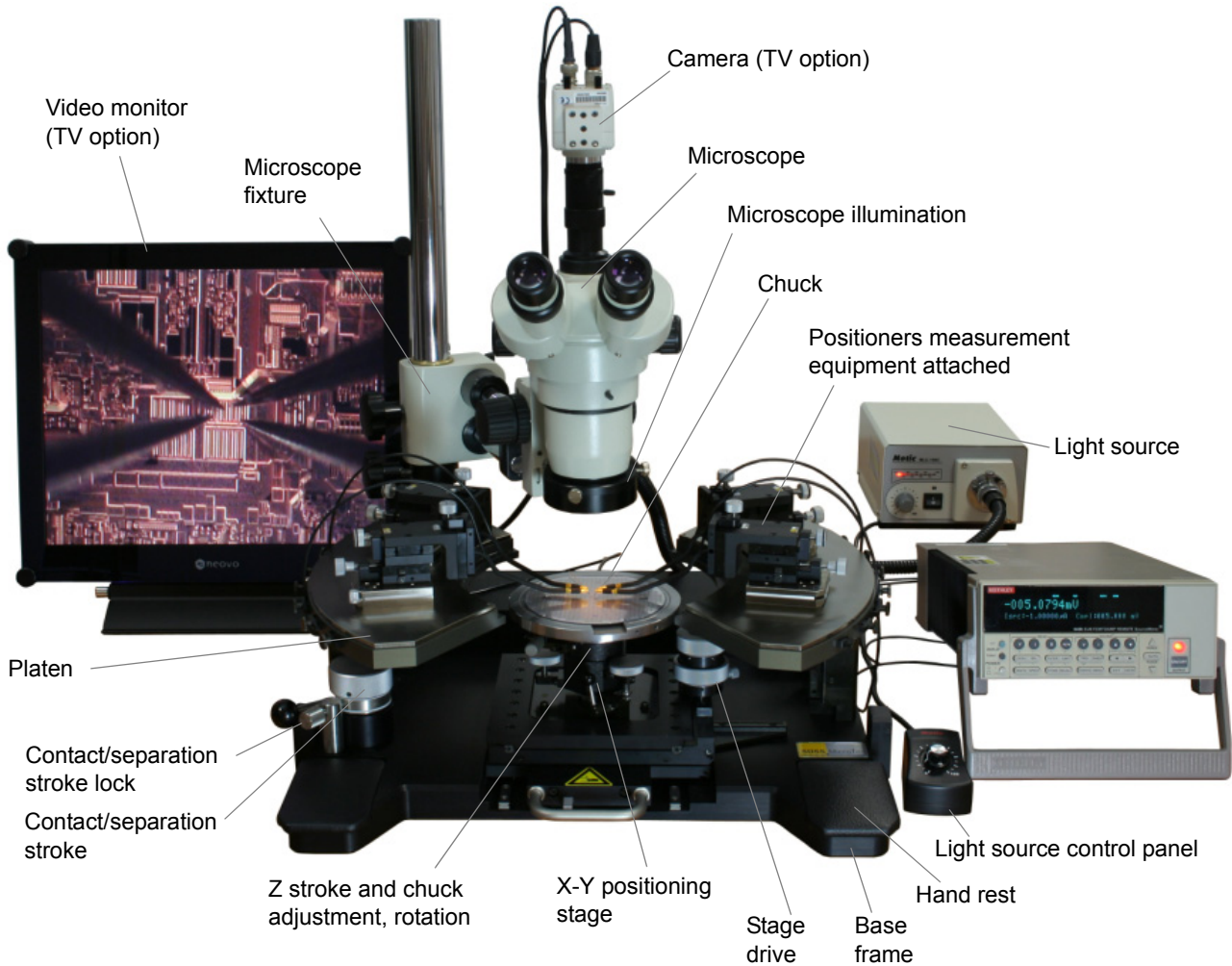

© Copyright 2011 Cascade Microtech, Inc. All rights reserved. Cascade Microtech is a registered trademark of Cascade Microtech, Inc. All other trademarks are the property of their respective owners.

Data subject to change without notice.

Cascade Microtech, Inc.
Corporate Headquarters
toll free: +1-800-550-3279
phone: +1-503-601-1000
email: cmj_sales@cmicro.com

Germany
phone: +49-89-9090195-0
email: cmj_sales@cmicro.com

Japan
phone: +81-3-5615-5150
email: cmj_sales@cmicro.com

China
phone: +86-21-3330-3188
email: cmj_sales@cmicro.com

Singapore
phone: +65-6873-7482
email: cms_sales@cmicro.com

Taiwan
phone: +886-3-5722810
email: cmt_sales@cmicro.com

